

ČESKOSLOVENSKÉ NORMY

KŘÍDLATÉ ŠROUBY

Rozměry v mm

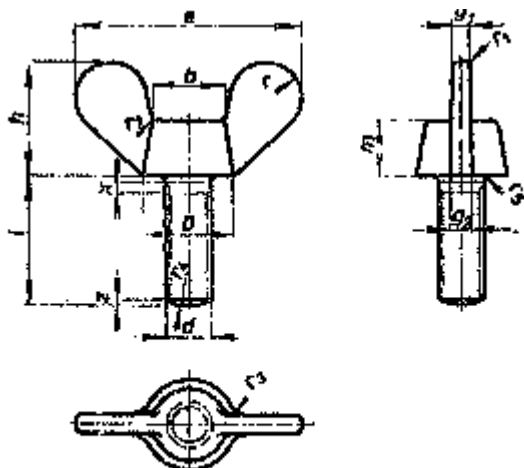

Označení křídlatého šroubu se závitem M10 a s délkou l = 30 mm:

Šroub M10 x 30 ČSN 02 1165

Závit d	M3	M4	M5	M6	M8	T0	M12
b	s	6	8	10	12	15	19
0	s	8	10	12	16	20	23
e	16	20	25	32	40	40	64
g1	1, 2	1, 6	2	2, 5	3	4	5
g2	1, 6	2	2, 5	3	4	5	6
h	B	10	12	16	20	25	32
m	4	5	6	8	10	12	14
r	2, 5	3	4	5	6	8	10
r1	0, 6	0, 8	1	1	i	1	t
r2	0, 5	0, 5	0, 5	1	1	1, 2	1, 2
r3	1, 6	2	2, 5	3	4	5	6
r4	2, 5	3	4	5	6	B	10
r5	0, 1	0, 2	0, 2	0, 3	0, 5	0, 5	1
x	1, 2	1, 6	2	2, 5	3	3, 5	4
z	0, 5	0, 7	0, 9	1	1, 5	1, 7	2
Délka l	Přibližná váha 1000 kusů kg						
4	1, 3?						
6	1, 45	2, 88	5, 50				
B	1, 54	3, 03	5, 74	11, 0			
10	1, 63	3, 19	5, 98	11, 4	23, 7		
12	1, 72	3, 34	6, 22	11, 7	24, 3		
15		3, 5?	6, 58	12, 3	25, 3	49, 0	82, 1
18			6, 94	12, 8	26, 3	50, 5	84, 1

20			7, 22	13, 2	26, 9	51, 5	85, 7
25				14, 1	28, 5	54, 0	89, 4
30 !					30, 1	5?, 6	93, 0
40						61, 5	too
50							108

Materiál: ocel 10 371 s mechanickými vlastnostmi 40 podle ČSN... Provedení: hrubé podle ČSN...
 Závit: metrický podle ČSN 1001. Technické dodací podmínky podle ČSN.....

ČSN 02 1165

Výběr

Červen 1949

Číslo řadicí

31 3172 30 1172

00209