

ŠROUBY S PŮLKULOVOU HLAVOU a s nose, do kovu

ČSN 021315

JK 311 11

d) Závit ⁴⁾	M 5	M 6	M 8	M 10	M 12	M 16	
b3)	16	18	22	26	30	38	
D	10	12	16	19	24	30	
g	2	2, 5	3	3, 2	3, 8	4, 2	
i min.	1, 8	2	2, 3	2, 7	3, 2	3, 5	
k	3, 5	4, 5	5, 5	7	9	11	
n	3, 2	3, 6	4, 2	4, 8	5, 8	6, 2	
R	0, 3	0, 3	0, 5	0, 5	1, 0	1, 2	
R	5, 7	6, 5	8, 9	10, 5	13, 3	15, 8	
Délka 1		Přibližná hmota 1000 šroubů				v kg5)	
16	3, 48	5, 55					
20	3, 97	6, 25	11, 8				
25	4, 59	7, 13	13, 4	23, 2			
30	5, 21	8, 01	15, 0	25, 7			
35	5, 83	8, 89	16, 6	28, 2	47, 1	84, 2	
40	6, 45	9, 77	18, 2	30, 7	50, 7	90, 8	
45	7, 07	10, 6	19, 8	33, 2	54, 3	97, 4	
50	7, 69	11, 5	21, 4	35, 7	57, 9	104, 0	
55	8, 31	12, 4	23, 0	38, 2	61, 5	111	
60	8, 93	13, 3	24, 6	40, 7	65, 1	118	

(Pokrač.)

Nahrazuje ČSN 02 1315 ze 7. 2. 1953

Účinnost od: 1. 1. 1967

00231

Болты с полукруглой головкой и усом для металла

Round-headed bolts with feather for metal

Rozměry v mm

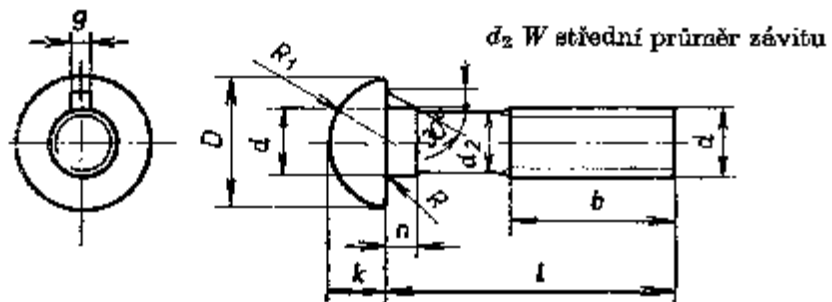

Označení šroubu s půlkulovou hlavou a s nosem, se závitem M 10, s délkou $l = 45$ mm a s mechanickými vlastnostmi 4D:

Šroub M 10 × 45 ČSN 02 1315